

| DIMENSIONS |     |      |     |     |         | (UNIT:mm)  |
|------------|-----|------|-----|-----|---------|------------|
| PUMP MODEL | A   | B    | C   | D   | E       | WEIGHT(kg) |
| AX1-52-P□□ | 198 | 54.5 | 193 | 219 | φ12Xφ18 | 3.7        |
| AX1-52-F□□ | 198 | 54.5 | 193 | 219 | φ10Xφ12 | 3.8        |
| AX1-13-P□□ | 204 | 54   | 192 | 222 | φ12Xφ18 | 4.1        |
| AX1-13-F□□ | 204 | 54   | 192 | 222 | φ10Xφ12 | 4.2        |

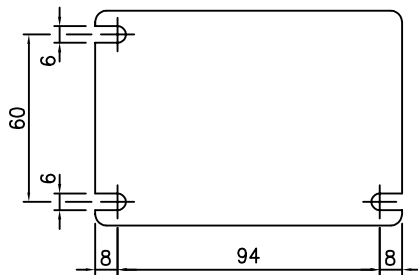

VIEW "A"

| PUMP SPECIFICATIONS (50Hz/60Hz)          |                                 |             |
|--|---------------------------------|-------------|
| PUMP MODEL                               | AX1-52                          | AX1-13      |
| MAXIMUM CAPACITY (ml/min)                | 460 / 550                       | 1040 / 1250 |
| MAX.DIS.PRESSURE (kgf/cm <sup>2</sup> G) | 3                               | 3           |
| STROKE PER MINUTE (SPM)                  | 114 / 136                       | 114 / 136   |
| MOTOR TYPE                               | Totally Enclosed Non-Ventilated |             |
| POWER (W)                                | 25                              | 37          |

| ITEM NO     | NO.       | DESCRIPTION | SIZE                         | MAT'L           | Q'TY     | REMARK |
|-------------|-----------|-------------|------------------------------|-----------------|----------|--------|
|             | MAT'L     | MAT'L DIM   | WEIGHT                       | SCALE           | N/S(0.5) |        |
|             | FILE NAME | A1ZPH-02    | 제명 TITLE                     | OUTLINE DRAWING |          |        |
|             | APPROVED  |             | AX1-52,13-Z PUMP (HOSE TYPE) |                 |          |        |
|             | CHECKED   |             |                              |                 |          |        |
|             | DESIGNED  |             | 제명 DWG NO                    | 141102          |          |        |
|             | DRAWN     |             |                              |                 |          |        |
| STORAGE NO. |           |             |                              |                 |          |        |
| ORG.DWG     |           |             |                              |                 |          |        |

천세산업 주식회사  
CHEON SEI IND. CO.,LTD.

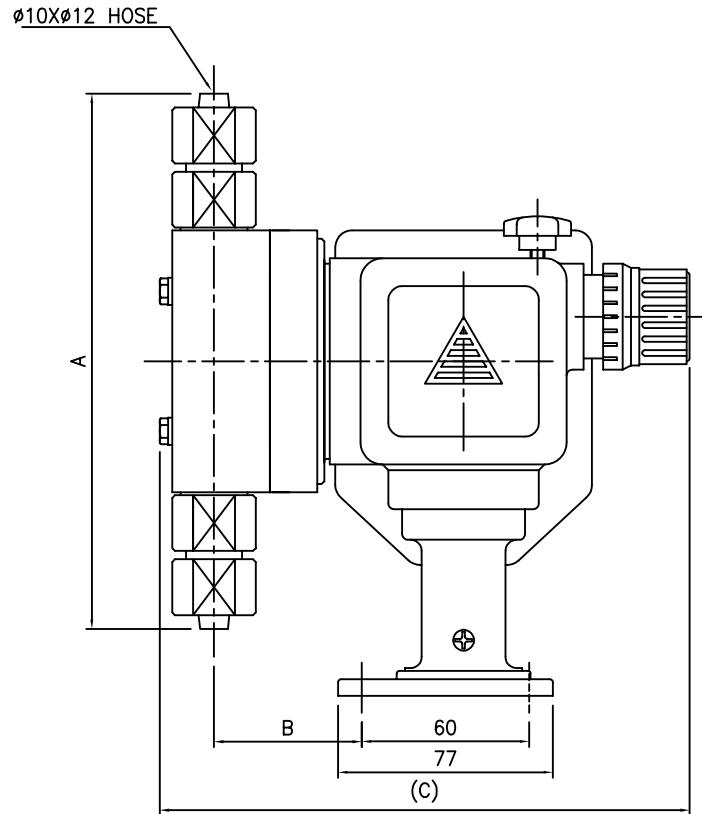
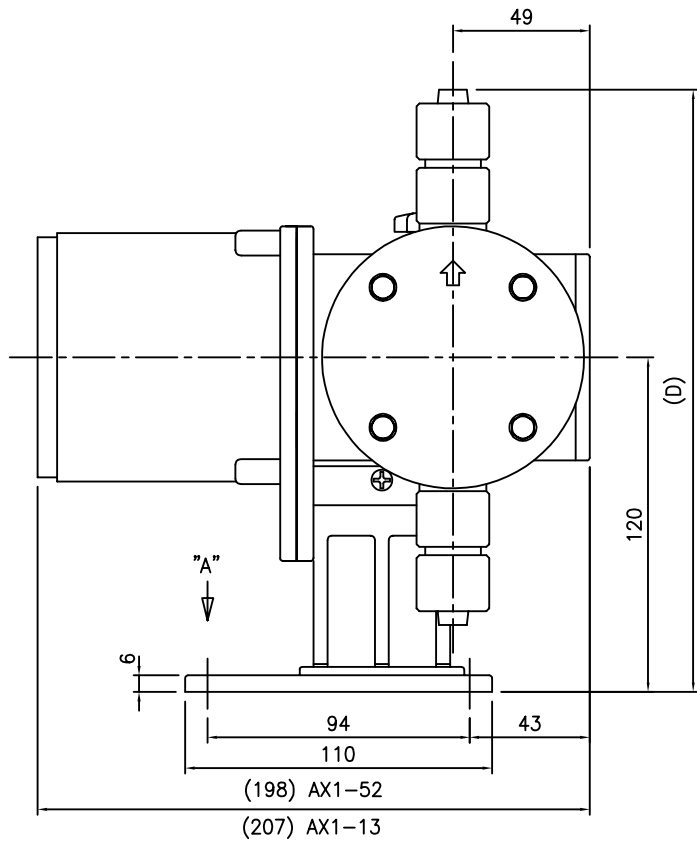

| PUMP MODEL | DIMENSIONS (UNIT:mm) |    |     |     | WEIGHT(kg) |
|------------|----------------------|----|-----|-----|------------|
|            | A                    | B  | C   | D   |            |
| AX1-52-S□□ | 192                  | 53 | 190 | 216 | 5.5        |
| AX1-52-6□□ |                      |    |     |     |            |
| AX1-13-S□□ | 198                  | 54 | 191 | 219 | 6.1        |
| AX1-13-6□□ |                      |    |     |     |            |

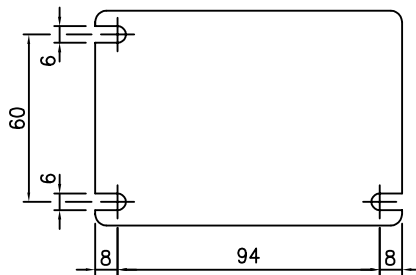

VIEW "A"

| PUMP SPECIFICATIONS (50Hz/60Hz)          |                                 |             |
|--|---------------------------------|-------------|
| PUMP MODEL                               | AX1-52                          | AX1-13      |
| MAXIMUM CAPACITY (ml/min)                | 460 / 550                       | 1040 / 1250 |
| MAX.DIS.PRESSURE (kgf/cm <sup>2</sup> G) | 3                               | 3           |
| STROKE PER MINUTE (SPM)                  | 114 / 136                       | 114 / 136   |
| MOTOR TYPE                               | Totally Enclosed Non-Ventilated |             |
| POWER (W)                                | 25                              | 37          |

| ITEM NO | NO.         | DESCRIPTION | SIZE                                 | MAT'L           | Q'TY           | REMARK |
|---------|-------------|-------------|--------------------------------------|-----------------|----------------|--------|
|         |             | MAT'L       | MAT'L DIM                            | WEIGHT          | SCALE N/S(0.5) |        |
|         | FILE NAME   | A1ZSH-02    | 専業 TITLE                             | OUTLINE DRAWING |                |        |
|         | APPROVED    |             | AX1-52,13-Z PUMP (HOSE TYPE)         |                 |                |        |
|         | CHECKED     |             | 専業 DWG NO 141152                     |                 |                |        |
|         | DESIGNED    |             |                                      |                 |                |        |
|         | DRAWN       |             | 천세산업 주식회사<br>CHEON SEI IND. CO.,LTD. |                 |                |        |
|         | STORAGE NO. |             |                                      |                 |                |        |
|         | ORG.DWG     |             |                                      |                 |                |        |